

## Wave Springs

The Abbey Seals Wave Spring Range of Bi-directional mechanical seals offer proven seal design and wave spring technology, in a range of material combinations, enhanced by superior design features, all at very competitive pricing.

### APPLICATIONS

The 1688 range was specifically designed for short working length and hygienic requirements, such as rotary lobe pumps. Their principle applications are often also for liquids of high viscosity. These are commonly found in the food, dairy, brewery and pharmaceutical industries. The compact design makes this seal an excellent choice for confined, shallow seal housing areas, or even external seal mounted applications.

The 1677 / 1678 Seal Type Series provide a high quality, general purpose seal, suitable for many sealing application requirements, including chemical duties.

### STANDARD ABBEY SEALS WAVE SPRING TYPES

#### Types 1677 and 1677M

The Type 1677 is a positively, driven wave spring seal, utilising crest to crest wave spring technology, offering excellent axial movement capabilities. The seal is radially compacted and designed to suit DIN24960 (EN12756). The design of this seal head enables easy utilisation of a wide range of high quality materials and elastomers, supplied as standard. Type 1677M differs in having a Monolithic seal head, for optimal heat dissipation and seal capability / performance.

#### Types 1678

Designed as per the Type 1677 but with a stepped face, to provide a balanced seal for stepped shafts.

#### Type 1688

The robust wave spring seal is ideally suited for standard, rotary lobe pump, glands, of compact design. The seal is positively driven by grub screws and supplied from Abbey Seals with Monolithic seal heads, in soft and hard face materials as our standard.

### STANDARD COMPONENTS



Type 1688 Series



Type 1677



Type 1677M Series



Type 1678

NO	DESCRIPTION	4	WAVE SPRING
1	FACE	5	GRUB SCREW
2	'O'-RING	6	BACKING PLATE
3	SLEEVE/RETAINER	7	FACE RETAINER

### ABBEE SEALS DESIGN ADVANTAGES

#### Type 1688 Superior Design

Type 1688 is supplied with a Monolithic rotary head, in both standard and hard face alternatives, to improve the seal operating performance in viscous fluids. This is achieved by eliminating the possibility of spinning and damage common to inserted face designs. Competitors inserted T.C. / SiC seal face rings are prone to spinning, particularly in the viscous or co-agulating fluids which are common to rotary lobe pump applications. Common, popular sizes of Type 1688 seals are fitted with our Sinusoidal Wave-Springs. These wave-springs offer a more consistent and accurate spring rate than traditional wave-springs. The Sinusoidal waves offer a larger and more even contact and the split over-lap minimises the working stresses, which frequently result in fracture, buckling or hang-up with a stamped, non-split, wave-spring.

#### Type 1677 and 1678 Superior Design

These seals utilise a double wave-spring. If the seal manufacturer's design solution is to use two wave-springs welded together, then this creates a weak spot, prone to both mechanical failure and corrosive attack. Abbey Seals Type 1677 / 1678 seals incorporate a one-piece designed, crest to crest wave spring, removing the possibility of corrosion to weld spots. This removes the most common seal failure mode on such seals.

The seals contain an energised rotary 'O'-Ring, reducing shaft fretting and ensuring positive shaft sealing. Our design has a chamfer at the front wall of the 'O'-Ring groove and a dynamic ring backing plate constantly energising and pressing the 'O'-Ring forward and down onto the shaft.

This overcomes 'O'-Ring hang-up on the shaft, the second common ultimate seal failure mode found on other manufacturer's designs.

#### Compact Seal

The uniform wave spring forces, provide excellent axial movement capabilities, compared to conventional mechanical seals. Use of a wave-spring allows the seal design to be very compact, giving an assured seal for short, confined glands.

### ABBEE SEALS WAVE SPRING TYPE SEALS PV CHART

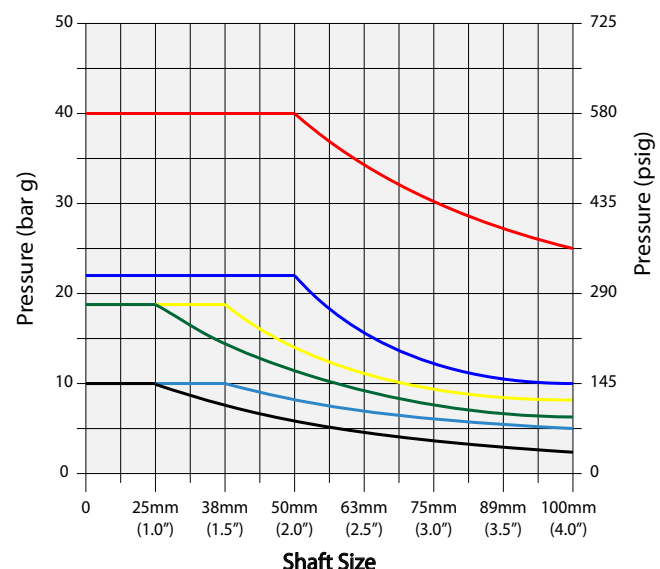

#### CHART BASED UPON: CARBON SEAL FACE VS SEAT FACE MATERIALS SHOWN BELOW

1678/M - Carbon/SiC	1682 - Carbon/SS
1677/M - Carbon/SiC	1688X - Carbon/TC
1682 - Carbon/TC	1688X - Carbon/SS

# TYPE 1677

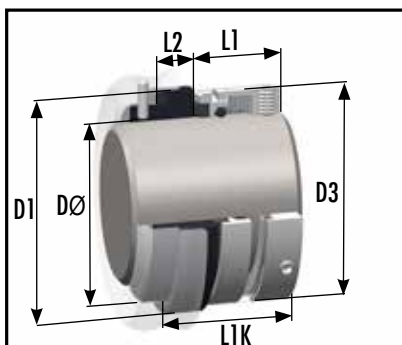
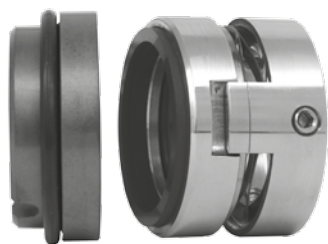

Sinusoidal wave-spring, 'O'-Ring mounted seal commonly utilised in the European chemical process industries. Manufactured to suit DIN24960 (EN12756) dimensions.

Supplied as Type 1677 with a stainless steel head retainer and inserted face. Or increasingly as Type 1677M with Monolithic head, see the page opposite. Stocked as a standard assembly with Type 8 DIN LONG 'O'-Ring seat with anti-rotation provision.

## ABBEY SEALS STANDARD SIZES

Metric Shaft Size DØ	Size Code	D1	D3	L1	L2	L1K	SLOT WIDTH	SLOT DEPTH
14*	0140	25.00	24.00	25.00	10.00	35.00	4.00	5.00
16	0160	27.00	26.00	25.00	10.00	35.00	4.00	5.00
18	0180	33.00	32.00	26.00	11.50	37.50	4.00	5.50
20	0200	35.00	34.00	26.00	11.50	37.50	4.00	5.50
22	0220	37.00	36.00	26.00	11.50	37.50	4.00	5.50
24	0240	39.00	38.00	28.50	11.50	40.00	4.00	5.50
25	0250	40.00	39.00	28.50	11.50	40.00	4.00	5.50
28	0280	43.00	42.00	31.00	11.50	42.50	4.00	5.50
30	0300	45.00	44.00	31.00	11.50	42.50	4.00	5.50
32	0320	48.00	46.00	31.00	11.50	42.50	4.00	5.50
33	0330	48.00	47.00	31.00	11.50	42.50	4.00	5.50
35	0350	50.00	49.00	31.00	11.50	42.50	4.00	5.50
38	0380	56.00	54.00	31.00	14.00	45.00	5.00	5.50
40	0400	58.00	56.00	31.00	14.00	45.00	5.00	5.50
43	0430	61.00	59.00	31.00	14.00	45.00	5.00	5.50
45	0450	63.00	61.00	31.00	14.00	45.00	5.00	5.50
48	0480	66.00	64.00	31.00	14.00	45.00	5.00	5.50
50	0500	70.00	66.00	32.50	15.00	47.50	5.00	5.50
53	0530	73.00	69.00	32.50	15.00	47.50	5.00	5.50
55	0550	75.00	71.00	32.50	15.00	47.50	5.00	5.50
58	0580	78.00	78.00	37.50	15.00	52.50	5.00	5.50
60	0600	80.00	80.00	37.50	15.00	52.50	5.00	5.50
63	0630	83.00	83.00	37.50	15.00	52.50	5.00	5.50
65	0650	85.00	85.00	37.50	15.00	52.50	5.00	5.50
68	0680	90.00	88.00	34.50	18.00	52.50	5.00	5.50
70	0700	92.00	89.00	42.00	18.00	60.00	5.00	5.50
75	0750	97.00	96.00	42.00	18.00	60.00	5.00	5.50
80	0800	105.00	104.00	41.80	18.20	60.00	5.00	5.50
85	0850	110.00	108.00	41.80	18.20	60.00	5.00	5.50
90	0900	115.00	114.00	46.80	18.20	65.00	5.00	5.50
95	0950	120.00	118.00	47.80	17.20	65.00	5.00	5.50
100	1000	125.00	124.00	47.80	17.20	65.00	5.00	5.50

All types, sizes and materials shown are part of Abbey Seals' Guaranteed Ex-Stock Range, unless marked with an asterisk\*. However, the asterisked seal and / or seat face materials are stocked in some, but not all, materials. And the asterisked materials in some sizes.

GUARANTEED STOCK MATERIALS AND FACE MATERIAL CODE					
Seal And Seat Assembly		Rotary Face		Stationary Face	
Face Reference Term	Code	Material	Code	Material	Code
SOFT	DB	M825 FDA Carbon	DB	99% Ceramic	A
SOFT VS HARD	DR	M825 FDA Carbon	DB	WNV2 SINSIC Carbide	S
HARD VS SOFT	RD	WNV2 SINSIC Carbide	R	M825 FDA Carbon	RD
HARD	R	WNV2 SINSIC Carbide	R	WNV2 SINSIC Carbide	R
HARD 1st ALT	H	Tungsten Carbide*	H	Tungsten Carbide*	H
Guaranteed Stock Elastomers: Viton®, E.P. and Nitrile			Guaranteed Stock Metallurgy: 316SS		

## Suggested Operating Limits

Maximum Operating Pressure Limits primarily depend upon Face Materials, Shaft Size, Speed and Media. Please refer to the Seal Type Specific PV Chart, found at the front of this Brochure Section, in combination with the Vulcan Multiplying Factors found in Technical and Material Standards Section 2.

# TYPE 1677M

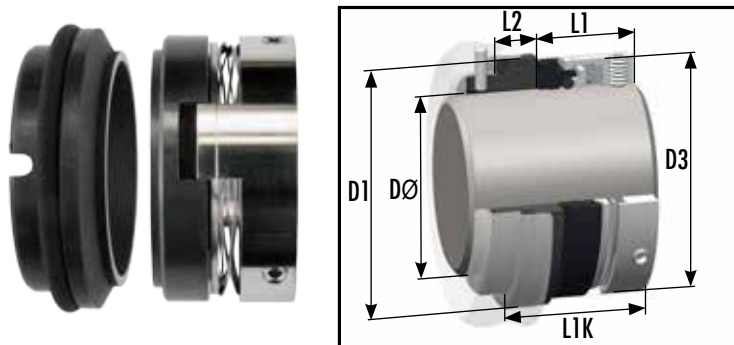

Sinusoidal wave-spring, 'O'-Ring mounted seal commonly utilised in the European chemical process industries. Manufactured to suit DIN24960 (EN12756) dimensions.

Type 1677M has a Monolithic head, instead of the inserted face as per the Type 1677, see the page opposite. Stocked as a standard assembly with Type 8 DIN LONG 'O'-Ring seat with anti-rotation provision. Monolithic Carbon stationary material option is illustrated.

## ABBEY SEALS STANDARD SIZES

Metric Shaft Size DØ	Size Code	D1	D3	L1	L2	L1K	SLOT WIDTH	SLOT DEPTH
14*	0140	25.00	24.00	25.00	10.00	35.00	4.00	5.00
16	0160	27.00	26.00	25.00	10.00	35.00	4.00	5.00
18	0180	33.00	32.00	26.00	11.50	37.50	4.00	5.50
20	0200	35.00	34.00	26.00	11.50	37.50	4.00	5.50
22	0220	37.00	36.00	26.00	11.50	37.50	4.00	5.50
24	0240	39.00	38.00	28.50	11.50	40.00	4.00	5.50
25	0250	40.00	39.00	28.50	11.50	40.00	4.00	5.50
28	0280	43.00	42.00	31.00	11.50	42.50	4.00	5.50
30	0300	45.00	44.00	31.00	11.50	42.50	4.00	5.50
32	0320	48.00	46.00	31.00	11.50	42.50	4.00	5.50
33	0330	48.00	47.00	31.00	11.50	42.50	4.00	5.50
35	0350	50.00	49.00	31.00	11.50	42.50	4.00	5.50
38	0380	56.00	54.00	31.00	14.00	45.00	5.00	5.50
40	0400	58.00	56.00	31.00	14.00	45.00	5.00	5.50
43	0430	61.00	59.00	31.00	14.00	45.00	5.00	5.50
45	0450	63.00	61.00	31.00	14.00	45.00	5.00	5.50
48	0480	66.00	64.00	31.00	14.00	45.00	5.00	5.50
50	0500	70.00	66.00	32.50	15.00	47.50	5.00	5.50
53	0530	73.00	69.00	32.50	15.00	47.50	5.00	5.50
55	0550	75.00	71.00	32.50	15.00	47.50	5.00	5.50
58	0580	78.00	78.00	37.50	15.00	52.50	5.00	5.50
60	0600	80.00	80.00	37.50	15.00	52.50	5.00	5.50
63	0630	83.00	83.00	37.50	15.00	52.50	5.00	5.50
65	0650	85.00	85.00	37.50	15.00	52.50	5.00	5.50
68	0680	90.00	88.00	34.50	18.00	52.50	5.00	5.50
70	0700	92.00	89.00	42.00	18.00	60.00	5.00	5.50
75	0750	97.00	96.00	42.00	18.00	60.00	5.00	5.50
80	0800	105.00	104.00	41.80	18.20	60.00	5.00	5.50
85	0850	110.00	108.00	41.80	18.20	60.00	5.00	5.50
90	0900	115.00	114.00	46.80	18.20	65.00	5.00	5.50
95	0950	120.00	118.00	47.80	17.20	65.00	5.00	5.50
100	1000	125.00	124.00	47.80	17.20	65.00	5.00	5.50

All types, sizes and materials shown are part of Abbey Seals' Guaranteed Ex-Stock Range, unless marked with an asterisk\*. However, some asterisked sizes are stocked in some, but not all, materials. And the asterisked materials in some sizes.

## Suggested Operating Limits

Maximum Operating Pressure Limits primarily depend upon Face Materials, Shaft Size, Speed and Media. Please refer to the Seal Type Specific PV Chart, found at the front of this Brochure Section, in combination with the Vulcan Multiplying Factors found in Technical and Material Standards Section 2.

GUARANTEED STOCK MATERIALS AND FACE MATERIAL CODE					
Seal And Seat Assembly		Rotary Face		Stationary Face	
Face Reference Term	Code	Material	Code	Material	Code
SOFT	DB	M825 FDA Carbon	DB	99% Ceramic	A
SOFT VS HARD	DR	M825 FDA Carbon	DB	WNV2 SiSiC Carbide	S
HARD VS SOFT	RD	WNV2 SiSiC Carbide	R	M825 FDA Carbon	RD
HARD	R	WNV2 SiSiC Carbide	R	WNV2 SiSiC Carbide	R
HARD 1st ALT	H	Tungsten Carbide*	H	Tungsten Carbide*	H
Guaranteed Stock Elastomers: Viton®, E.P. and Nitrile			Guaranteed Stock Metallurgy: 316SS		

# TYPE 1678

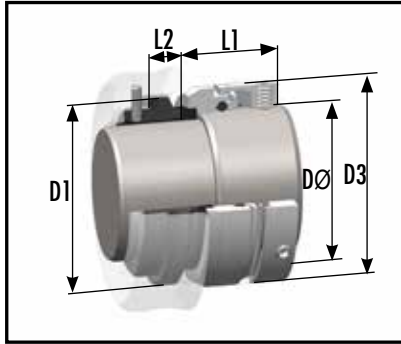

Stepped shaft, balanced sinusoidal wave-spring, 'O'-Ring mounted seal, similar to Type 1677, most commonly utilised in higher-pressure pump applications. Abbey Seals Types 1677, 1677M and 1678 all have sinusoidal continuous wave-springs without joints or weld-spots, for maximum spring reliability.

Stocked as a standard assembly with "stepped-size down" Type 8 DIN LONG 'O'-Ring seat with anti-rotation provision. Monolithic SiC stationary is illustrated.

## ABBEY SEALS STANDARD SIZES

Seal Shaft Size DØ	Seal Size Code	Seat Shaft Size	D1	D3	L1	L2	SEAT SLOT WIDTH	SEAT SLOT DEPTH
18*	0180	14	25.00	32.00	32.50	10.00	4.00	5.00
20*	0200	16	27.00	34.00	32.50	10.00	4.00	5.00
22*	0220	18	33.00	36.00	33.50	11.50	4.00	5.50
24*	0240	20	35.00	38.00	33.50	11.50	4.00	5.50
28	0280	24	39.00	42.00	36.00	11.50	4.00	5.50
30	0300	25	40.00	44.00	36.00	11.50	4.00	5.50
33	0330	28	43.00	47.00	38.50	11.50	4.00	5.50
35	0350	30	45.00	49.00	38.50	11.50	4.00	5.50
38	0380	33	48.00	54.00	38.50	11.50	4.00	5.50
40	0400	35	50.00	56.00	38.50	11.50	4.00	5.50
43	0430	38	56.00	59.00	38.50	14.00	5.00	5.50
45	0450	40	58.00	61.00	38.50	14.00	5.00	5.50
50*	0500	45	63.00	66.00	38.50	14.00	5.00	5.50
53*	0530	48	66.00	69.00	38.50	14.00	5.00	5.50
55*	0550	50	70.00	71.00	42.50	15.00	5.00	5.50
60*	0600	55	75.00	80.00	42.50	15.00	5.00	5.50
65*	0650	60	80.00	85.00	47.50	15.00	5.00	5.50

All types, sizes and materials shown are part of Abbey Seals' Guaranteed Ex-Stock Range, unless marked with an asterisk\*. However, some asterisked sizes are stocked in some, but not all, materials. And the asterisked materials in some sizes.

GUARANTEED STOCK MATERIALS AND FACE MATERIAL CODE					
Seal And Seat Assembly		Rotary Face		Stationary Face	
Face Reference Term	Code	Material	Code	Material	Code
SOFT	DB	M825 FDA Carbon	DB	99% Ceramic	A
SOFT VS HARD	DR	M825 FDA Carbon	DB	WNV2 SiNSiC Carbide	S
HARD VS SOFT	X	Non-standard: Please use 1678M "Hard vs Soft" or enquire.			
HARD	R	WNV2 SiNSiC Carbide	R	WNV2 SiNSiC Carbide	R
HARD 1st ALT	H	Tungsten Carbide*	H	Tungsten Carbide*	H
Guaranteed Stock Elastomers: Viton®, E.P. and Nitrile			Guaranteed Stock Metallurgy: 316SS		

## Suggested Operating Limits

Maximum Operating Pressure Limits primarily depend upon Face Materials, Shaft Size, Speed and Media. Please refer to the Seal Type Specific PV Chart, found at the front of this Brochure Section, in combination with the Vulcan Multiplying Factors found in Technical and Material Standards Section 2.

# TYPE 1688

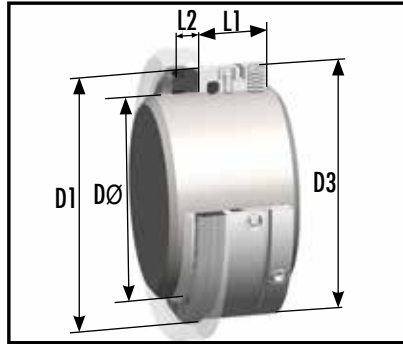

Wave spring 'O'-Ring mounted mechanical seal with narrow cross-section, short working length and set-screw drive. Most commonly installed on lobe-rotor pumps, where the twin-shafts and compact pump design make this very compact seal an ideal solution. Lobe-rotor pumps are extensively found in the food, process and dairy industries. The Type 1688 has been optimally designed for such confined spaces and hygienic applications. And further benefits from our monolithic head and one piece sinusoidal wave-spring .

## ABBEY SEALS STANDARD SIZES

Imperial Shaft Size DØ	Metric Shaft Size DØ	Size Code	D1	D3	L1	L2
0.625		0158	28.50	27.00	19.10	6.30
	16	0160	28.50	27.00	19.10	6.30
0.750		0191	31.70	30.00	19.10	6.30
	24	0240	35.40	34.10	19.10	7.60
	28	0280	42.00	39.00	19.10	7.60
1.125		0286	41.20	39.50	19.10	7.60
	30	0300	42.70	41.00	19.10	7.60
1.250		0317	44.40	42.40	19.10	7.60
	32	0320	44.40	42.40	19.10	7.60
1.375		0349	47.60	45.50	19.10	7.60
	35	0350	47.60	45.50	19.10	7.60
	38	0380	53.90	51.80	21.10	8.10
1.500		0381	53.90	51.80	21.10	8.10
1.750		0444	60.30	58.20	21.10	8.10
1.875		0476	63.50	61.40	21.10	8.10
	50	0500	63.90	61.90	21.10	8.10
2.000		0508	66.60	64.60	21.10	9.60
2.125		0539	73.02	71.00	22.10	9.60
	54	0540	73.95	71.00	22.10	9.60
	54.6	0546	75.00	72.00	22.10	9.60
	55	0550	75.00	72.00	22.10	9.60
	63	0630	83.00	79.30	25.80	9.10
2.500		0635	88.90	79.30	25.80	9.10
2.750		0698	95.25	90.80	25.80	9.10
2.875		0730	98.43	94.00	25.80	9.10
	75	0750	100.40	96.00	25.80	9.10
3.000		0762	101.60	96.90	25.80	9.10
	80	0800	104.00	101.00	25.80	9.10
	95	0950	125.00	116.00	25.80	9.10
	100	1000	130.00	121.00	25.80	9.10

All types, sizes and materials shown are part of Abbey Seals' Guaranteed Ex-Stock Range, unless marked with an asterisk\*. However, the asterisked seal and / or seat face materials are stocked in many, but not all, sizes.

## Suggested Operating Limits

Maximum Operating Pressure Limits primarily depend upon Face Materials, Shaft Size, Speed and Media. Please refer to the Seal Type Specific PV Chart, found at the front of this Brochure Section, in combination with the Vulcan Multiplying Factors found in Technical and Material Standards Section 2.

GUARANTEED STOCK MATERIALS AND FACE MATERIAL CODE					
Seal And Seat Assembly		Rotary Face		Stationary Face	
Face Reference Term	Code	Material	Code	Material	Code
SOFT	P	304 Stainless Steel	P	M106K Carbon	C
SOFT VS HARD	X	Non-standard: please use alternative shown below or enquire			
HARD VS SOFT	U	Tungsten Carbide	H	M106K Carbon	C
HARD	H	Tungsten Carbide	H	Tungsten Carbide	H
HARD 1st ALT	X	Non-standard: please use alternative shown here or enquire			
Guaranteed Stock Elastomers: Viton®, E.P. and Nitrile			Guaranteed Stock Metallurgy: 304SS		